

PROFLAME™ INTEGRATED FLAME SCANNER

Model ZPF-130



BURNERS | FLARES | THERMAL OXIDIZERS | VAPOR CONTROL | RENTALS | AFTERMARKET



The ZEECO® ProFlame™ integrated flame scanner revolutionizes the industry by providing reliable flame detection and instant flame status for safer operation. **Easy to configure, simple to set up, the Model ZPF-130 is uniquely designed for use in non-hazardous (safe) areas.**

Design Features and Benefits

- Compact and exceptionally reliable
- State-of-the-art digital signal processing for easy flame analysis
- Easily configurable frequency and gain settings for simple set-up
- Intuitive display to assist in troubleshooting
- Dual signal channel with electronic self-check for SIL3 applications
- Aiming feature reduces commissioning time when sighting the flame scanner
- Durable housing for a variety of operating environments
- Low power consumption with a 24V dc supply
- Reliable 4-to-20 mA flame intensity output

Operating Environment

- Temperature: -40°F (-40°C) to 167°F (75°C)
- Relative humidity: 0% to 99.5% non-condensing
- Environmental protection rating: IP 67, NEMA 4X
- Vibration fatigue limit: 4 g (function tested to 5 g)
- Weight: 1.3 lbs (0.6 kg)
- Housing material: aluminum, polished finish
- Mounting Nipple: 1" NPT M, integral sealing window and noise/heat barrier*
- Cable: quick disconnect, 8 conductor cable*

* Ordered Separately

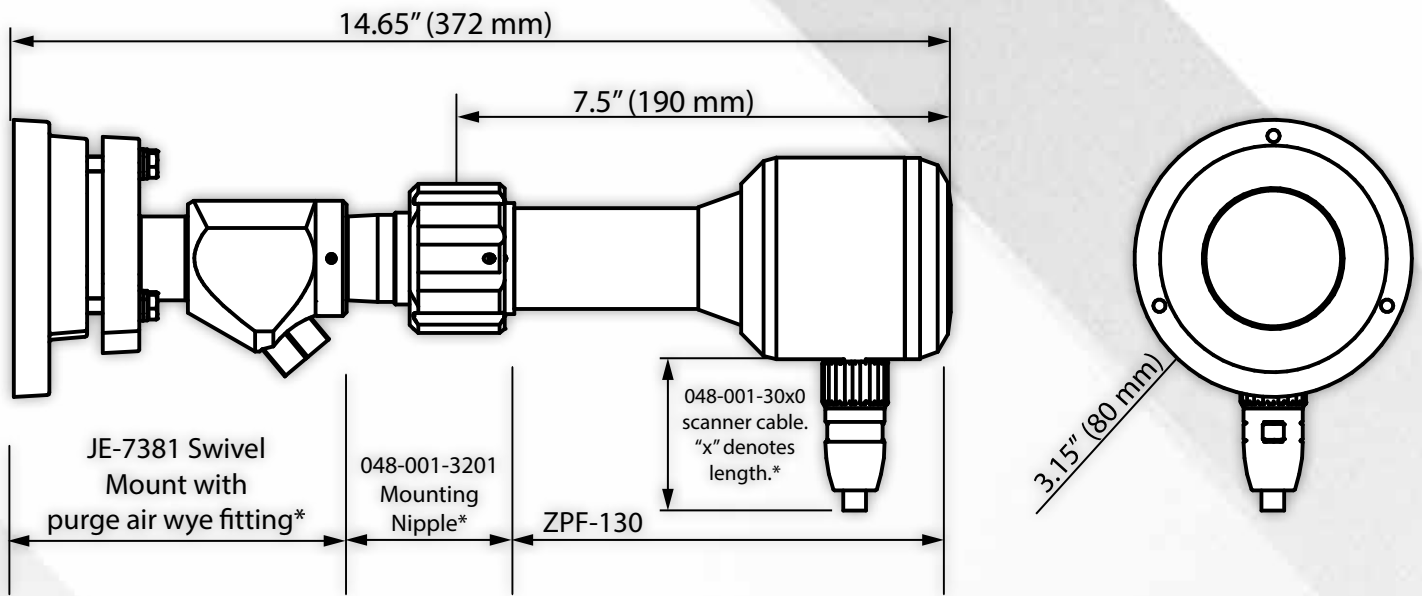

* Ordered Separately

Operating Parameters - Input

Input voltage

Supply voltage: 24V dc \pm 20%, protection class III

Power consumption: 4 W

Purge air

Cool, dry, clean air: 5 scfm (142 l/min) at 5" wc (12.5 mbar) above windbox or furnace pressure (sight tube exit point), \leq 100°F (38°C) at wye fitting

Operating Parameters - Output

- Output relay: SPDT, Flame-On is the N.O. contact and Flame-Off is the N.C. contact
- Contact rating: 48V dc at 0.5 A; 120Vac at 0.125A
- Flame intensity output: 4 to 20 mA referenced to 24V dc common; 220 Ω at 6.6V (\pm 2%)
- Flame status indication: Flame-On LED, Flame-Off LED, Flame intensity bar graph

The Zeeco Difference



Our only business is the combustion business. By concentrating on what we do best, Zeeco has grown into a worldwide leader in combustion solutions. We are a privately held company whose ownership stays highly involved in daily operations, with upper management comprised of the world's leading combustion experts.

When you call Zeeco, we answer. When you make a request, you get a quick, efficient response. We are lean and efficient, able to make decisions quickly, without bureaucracy and red tape. Our sales, engineering, and purchasing groups work hand-in-hand to deliver highly competitive quotes and heroic turnaround times. We stand ready and willing to travel anywhere in the world to discuss upcoming projects firsthand, and to ensure that every existing project runs seamlessly.

Zeeco Headquarters
22151 East 91st Street
Broken Arrow, OK 74014

Learn more at zeeco.com

✉ sales@zeeco.com

☎ +1 (918) 258 8551

Certifications apply to Zeeco Headquarters.



CERTIFIED
NBBI

CERTIFIED
ASME

CERTIFIED
ASME

REGISTERED
ISO 9001: 2015

Visit zeeco.com/contact
for additional Global Location
contact information



GO
ZEECO

Choose to work with our dedicated, flexible, and innovative team, and you won't be disappointed. Call or email us today to request a quote or to learn more about our proprietary combustion systems.