

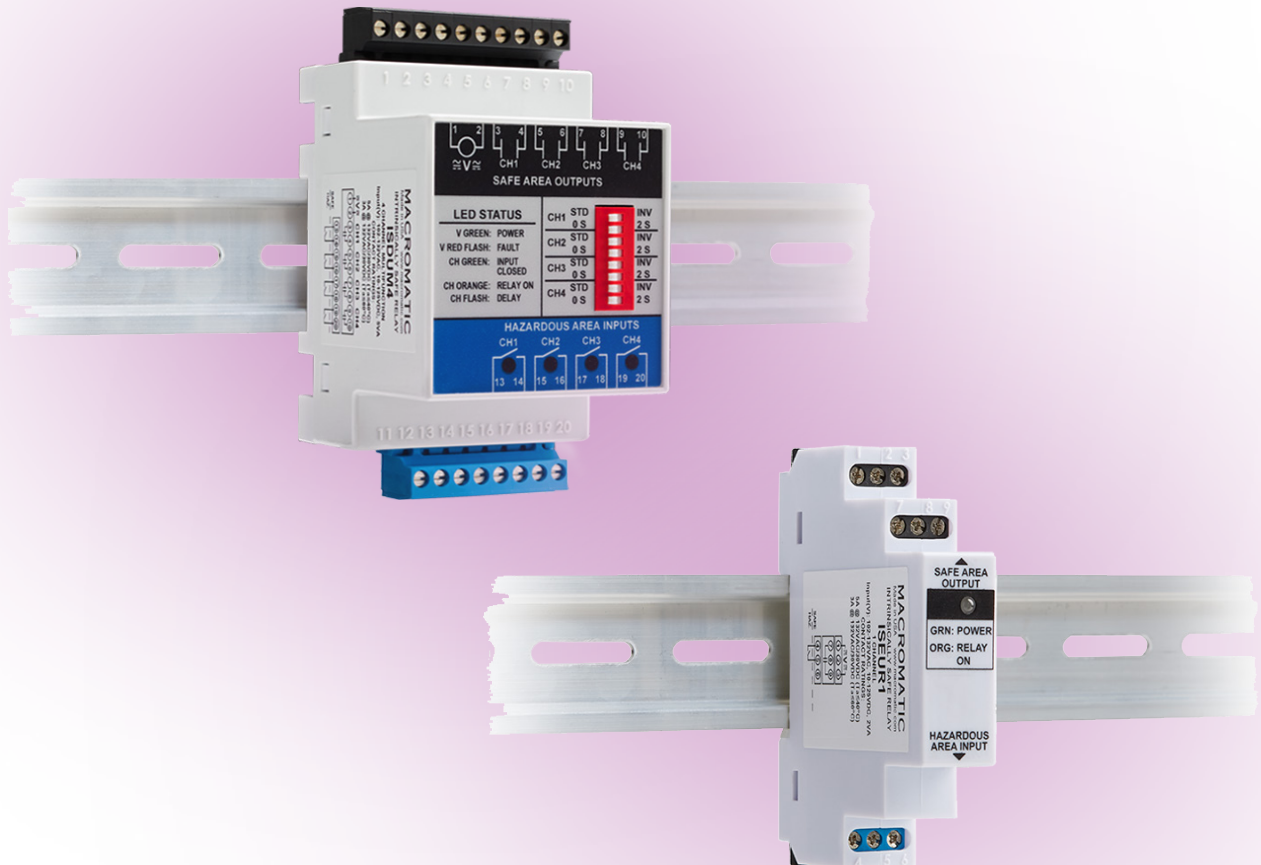

Better. By Design.

INTRINSICALLY SAFE PRODUCTS



CATALOG OF PRODUCTS

HAZARDOUS LOCATIONS OVERVIEW

When electrical equipment is used in, around, or near an atmosphere that has flammable gases or vapors, flammable liquids, combustible dusts, ignitable fibers or flyings, there is always a possibility or risk that a fire or explosion might occur. Those areas where the possibility or risk of fire or explosion might occur, due to an explosive atmosphere and/or mixture, are often called hazardous (or classified) locations. Currently, there are two systems used to classify these hazardous locations: the Class/Division system, used predominately in the United States, and the Zone system, generally used in the rest of the world.

What's Needed for An Explosion?

The most common types of reaction are between flammable gases, vapors or dust with oxygen in the surrounding air. As a rule, three basic requirements must be met for an explosion to take place in atmospheric air:

1. Flammable substance
2. Oxygen
3. Source of Ignition (a spark or high heat)

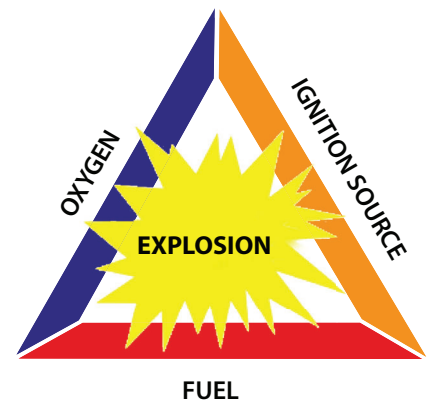

Note: both the flammable substance and the oxygen must be present in the correct mixture for the explosion to happen.

How is the Explosion Controlled?

The objective of selecting electrical equipment and the means of installation is to reduce the hazard of the electrical equipment to an acceptable level. The most certain method of preventing an explosion is to locate electrical equipment outside of hazardous (classified) areas whenever possible. In situations where this is not practical, installation techniques and enclosures are available which meet the requirements for locating electrical equipment in such areas. These methods of reducing hazards are based on the elimination of one or more of the elements of the ignition triangle discussed earlier.

Three principles ensure that electrical equipment does not become a source of ignition:

1. **Contain the explosion:** measures must be taken to ensure the explosion cannot spread to the surrounding atmosphere (explosion-proof enclosures or conduit & cable seals)
2. **Isolate the hazard:** the surrounding atmosphere is prevented from entering the enclosure by maintaining a positive pressure of inert gas or clean air within the unit (pressurization and purging, oil immersion & hermetic sealing)
3. **Limit the energy:** potentially explosive mixtures can penetrate the enclosure but must not be ignited. Sparks and raised temperatures must only occur within certain limits (intrinsic safety)

All Macromatic IS Series Intrinsically Safe Relays follow the third principal: **limit the energy utilizing an intrinsically safe circuit.**

HAZARDOUS LOCATION CLASSIFICATIONS

Standard classification systems provide a concise description of the hazardous material that may be present along with the probability of it being present so that the appropriate equipment may be used and safe installation practices followed. In North America, the classification system most widely used is defined by the NFPA Publication 70, NEC and CEC. They define the type of hazardous substances that is or may be present in the air in sufficient quantities to produce an explosion. The NFPA establishes area classifications based on Classes, Divisions and Groups which are factors combined to define the hazardous conditions of a specific area.

The table below summarizes the various hazardous (classified) locations:

| Substance | Substance Class | Area Classification | | Hazardous Location Characteristics |
|------------------|------------------------|---------------------|----------------|--------------------------------------------------------------------------------------------------------------------------------|
| | | NEC500 | NEC505 | |
| Gases/ Vapors | Class I (NEC 501) | Division 1 | Zone 0 | Explosion hazard present continuously or occasionally under normal operating conditions |
| | | | Zone 1 | |
| | | Division 2 | Zone 2 | Ignitable concentrations of flammable gases or vapors are not normally present, but could be present in the case of a fault |
| Dusts | Class II (NEC 502) | Division 1 | Zone 20 | Combustible dusts are present in quantities sufficient to produce explosive and ignitable |
| | | | Zone 21 | |
| | | Division 2 | Zone 22 | Combustible dust due to abnormal operations may be present in quantities sufficient to produce explosive or ignitable mixtures |
| Fibers | Class III (NEC 503) | Division 1 | Not equivalent | Easily ignitable fibers/flyings are handled or manufactured |
| | | Division 2 | | Easily ignitable fibers/flyings are stored or handled |

The Macromatic ISD & ISE Series of Intrinsically Safe Relays are certified Class I, Division 1 in the United States and Class I, Zones 0 and 1 in Canada.

The Macromatic ISD & ISE Series of Intrinsically Safe Relays have been tested and approved for listing under Underwriters Laboratory (UL) 913 Intrinsically Safe Apparatus and Associated Apparatus 8th Edition. The Macromatic ISP Series of Intrinsically Safe Relays have been tested and approved for listing under Underwriters Laboratory (UL) 913 Intrinsically Safe Apparatus and Associated Apparatus 6th Edition. The input or inputs to these devices have been approved for use in all Classes, Groups and Divisions.

60 MM INTRINSICALLY SAFE BARRIER RELAYS

ISD SERIES

INTRINSICALLY SAFE BARRIER RELAYS | DIN RAIL

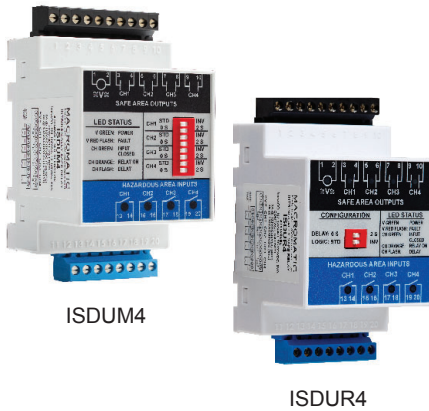

- ◆ Approved for use in these Hazardous Locations:
 - Class I, Div 1 (Zones 0 and 1 Canada), Groups A, B, C, D
 - Class II, Div 1 (Zones 20 and 21 Canada), Group E, F, G
 - Class III, Div 1
- ◆ 4-Channel
- ◆ Terminals support 2-wire inputs
- ◆ Isolated 5A relay outputs
- ◆ Pluggable terminals offer easy installation & replacement
- ◆ Universal input voltage of 102-132V AC & 10-125V DC
- ◆ Compact 60mm wide enclosure for both DIN-rail or panel-mount
- ◆ Standard & inverse logic
- ◆ Instantaneous & delayed response times
- ◆ LED status indicator



 UL913 8th Edition



Better. By Design.

800.238.7474
WWW.MACROMATIC.COM
SALES@MACROMATIC.COM

The ISD Series of Intrinsic Safe Barrier Relays provide a safe and reliable method to control up to four loads (motor starters, relays, etc.) with up to four input devices (switches, sensors, etc.) located in a hazardous area.

The ISD Series relays utilize a compact 60mm wide enclosure that can be both mounted on 35mm DIN rail or panel-mounted with two screws. Terminals for the input devices from the hazardous area are on the bottom of the unit for easy access in the enclosure to incoming field wiring from the hazardous area. Pluggable terminal blocks on both the input and output sides allow for easy initial wiring of the unit as well as replacement without having to remove any wires.

Each input has two terminals supporting direct connection of 2-wire input devices eliminating the need to mount a separate terminal block. Each output relay is isolated with two wiring terminals providing a true normally-open contact. This allows the output contacts to be used in complex control circuits and allows for each output to switch different voltages with respect to other outputs and the input voltage. A universal input voltage of 102-132V AC & 10-125V DC covers a variety of applications with one device.

Operation

Each ISD Series product consists of 4 intrinsically safe inputs and four corresponding normally-open relay outputs. With input voltage applied, the V LED will be ON (GREEN) to indicate power is applied. When the input device is closed, the input LED is ON (GREEN). When the output relay is closed, the output LED is ON (ORANGE). The ISD series offers four user-selectable configurations built in.

ISDUR4 has a two-position DIP-switch that selects a single configuration for all channels.

ISDUM4 has an eight-position DIP-switch that selects a configuration for each channel, independently.

Configurations

Standard Logic (DIP Switch set to "STD"):

When the input device is closed, the corresponding output contact is closed. When the input device is open, the corresponding output contact is open.

Inverse Logic (DIP Switch set to "INV"):

When the input device is open, the corresponding output contact is closed. When the input device is closed, the corresponding output contact is open.

No Time Delay (DIP Switch set to "0 S"):

The output contact changes state immediately in response to a change in input device state.

2 Second Delay (DIP Switch set to "2 S"):

The output contact will delay 2 seconds before changing state in response to a change in input device state.

| CONTROL VOLTAGE | NUMBER OF CHANNELS | CONFIGURATION | CATALOG NUMBER | WIRING |
|--------------------------------------|--------------------|---------------------------|----------------|---------------------------------------------------------------------------------------|
| 102-132V AC (50/60Hz) and 10-125V DC | 4 | SELECTED FOR ALL CHANNELS | ISDUR4 |  |
| | | SELECTED FOR EACH CHANNEL | ISDUM4 |  |

DIAGRAM 814

60 MM INTRINSICALLY SAFE BARRIER RELAYS

ISD SERIES

APPLICATION DATA

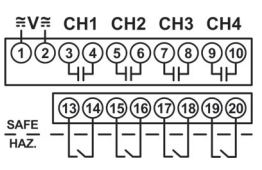
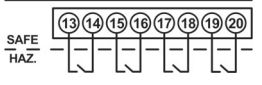
Input Voltage: 102-132V AC (50/60Hz.) & 10-125V DC

Load (Burden): 5VA Maximum

Input Switch Open Circuit Voltage: 10V DC

Output Contacts:

SPST-NO (Form A) 3A Resistive @ 125V AC @60°C & 30V DC Resistive, Pilot Duty Rating D300

SPST-NO (Form A) 5A Resistive @ 125V AC @40°C & 30V DC Resistive, Pilot Duty Rating D300

Life:

Electrical: 50,000 Closures @ Full Load AC

Mechanical: 5 Million Closures @ No Load

Response Times:

Standard (DIP Switch set to "0S"): < 50ms

Delay (DIP Switch set to "2S"): Fixed 2 Seconds

Temperature:

Operating: -28° to + 60° C (-18° F to +140° F)

Storage: -55° to +85° C (-67° to 185° F)

LED Indication:

V: ON (Green); Inputs: ON (Green); Outputs: ON (Orange)

Insulation Voltage:

1500 V AC between coil & contacts

750 V AC between open contacts

1500 V AC between contacts of different output channels

1500 V AC between hazardous and safe circuits

Wire Sizes:

One #14-24 AWG Conductor or

Two #16 or 18 AWG Conductors

Mounting:

Mounts on 35mm DIN-rail or panel-mounted with two #8 screws when DIN-rail clips are fully extended from under the enclosure.

Control Drawing:

See Instruction Sheet 901-0000-328, which includes Control Drawing ISD1A04.

Approvals:



ACCESSORIES

Terminal Kit Part # 70700: Replacement kit for Intrinsically Safe Barrier Relay plugable terminals, includes 1 black and 1 blue block.

Input Voltage: 102-132V AC and 10-125V DC

Output: 5A



Kit Part # 70700

DIMENSIONS

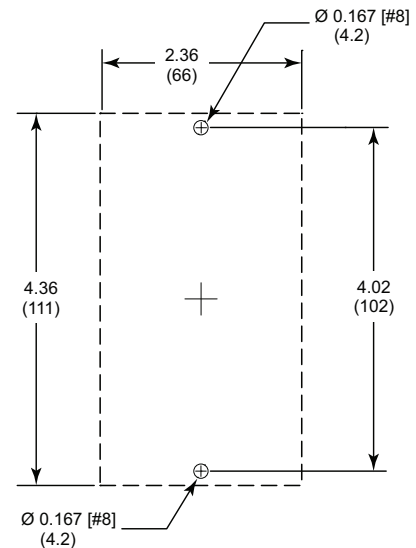
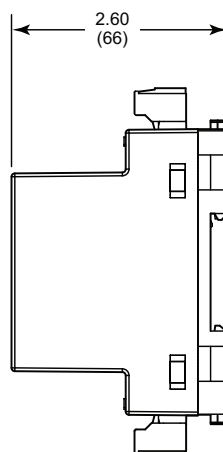
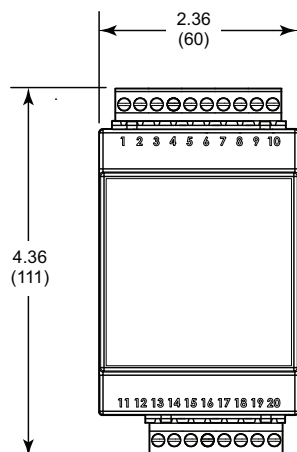

All Dimensions in Inches (Millimeters)

Panel Mount Template

17.5 MM INTRINSICALLY SAFE BARRIER RELAYS

ISE SERIES



- ◆ Approved for use in these Hazardous Locations:
Class I, Div 1 (Zones 0 and 1 Canada), Groups A, B, C, D
Class II, Div 1 (Zones 20 and 21 Canada), Group E, F, G
Class III, Div 1
- ◆ 1-Channel
- ◆ Terminals support 2-wire inputs
- ◆ Isolated 5A relay output
- ◆ Universal input voltage of 102-132V AC & 10-125V DC
- ◆ Compact 17.5mm wide enclosure for both DIN-rail or panel-mount
- ◆ Standard and Inverse Logic
- ◆ LED status indicator

 **UL** US
UL913 8th Edition



Better. By Design.

800.238.7474

WWW.MACROMATIC.COM

SALES@MACROMATIC.COM

The ISE Series of Intrinsically Safe Barrier relays provide a safe and reliable method to control a single load (motor starters, relays, etc.) with a single input device (switches, sensors, etc.) located in a hazardous area.

The compact 17.5mm wide enclosure can be both mounted on 35mm DIN rail or panel-mounted with two screws. Terminals for the input devices from the Hazardous area are on the bottom for easy access in the enclosure to incoming field wiring from the hazardous area.

Operation

Each ISE Series relay consists of an intrinsically safe input, a corresponding normally-open relay output, and a bi-color LED for status indication. With input voltage applied, the LED will be ON (GREEN) to indicate power is applied. When the output contact is closed, the LED is ON (ORANGE). The ISE series comes in Standard and Inverted configurations.

Configurations

Standard Logic (ISEUR1):

When the input device is closed, the corresponding output contact is closed. When the input device is open, the corresponding output contact is open.

Inverse Logic (ISEUR1V):

When the input device is open, the corresponding output contact is closed. When the input device is closed, the corresponding output contact is open.

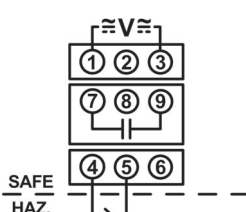
| CONTROL VOLTAGE | NUMBER OF CHANNELS | CONFIGURATION | CATALOG NUMBER | WIRING |
|--------------------------------------|--------------------|----------------|----------------|-----------------------------------------------------------------------------------------------------------------|
| 102-132V AC (50/60Hz) and 10-125V DC | 1 | STANDARD LOGIC | ISEUR1 |  <p>DIAGRAM 811</p> |
| | | INVERSE LOGIC | ISEUR1V | |

17.5 MM INTRINSICALLY SAFE BARRIER RELAYS

ISE SERIES

APPLICATION DATA

Input Voltage: 102-132V AC (50/60Hz.) & 10-125V DC

Load (Burden): 2VA Maximum

Input Switch Open Circuit Voltage: 10V DC

Output Contacts:

SPST-NO (Form A) 3A Resistive @ 125V AC @ 60°C & 30V DC Resistive, Pilot Duty Rating D300

SPST-NO (Form A) 5A Resistive @ 125V AC @ 40°C & 30V DC Resistive, Pilot Duty Rating D300

Life:

Electrical: 50,000 Closures @ Full Load AC

Mechanical: 5 Million Closures @ No Load

Response Times: < 50ms

Temperature:

Operating: -28° to + 60° C (-18° F to +140° F)

Storage: -55° to +85° C (-67° to 185° F)

LED Indication:

Standard Logic, ON (Green) - Input voltage; ON (Orange) - Input closed and output contact closed;

Inverse Logic (V-suffix), ON (Green) - Input voltage; ON (Orange) - Input open and output contact closed

Insulation Voltage:

1500 V AC between coil & contacts

750 V AC between open contacts

1500 V AC between hazardous and safe circuits

Wire Sizes:

One #14-24 AWG Conductor or

Two #16 or 18 AWG Conductors

Mounting:

Mounts on 35mm DIN-rail or panel-mounted with two #8 screws when DIN-rail clips are fully extended from under the enclosure.

Control Drawing:

See Instruction Sheet 901-0000-329, which includes Control Drawing ISD2A01.

Approvals:



E318075

DIMENSIONS

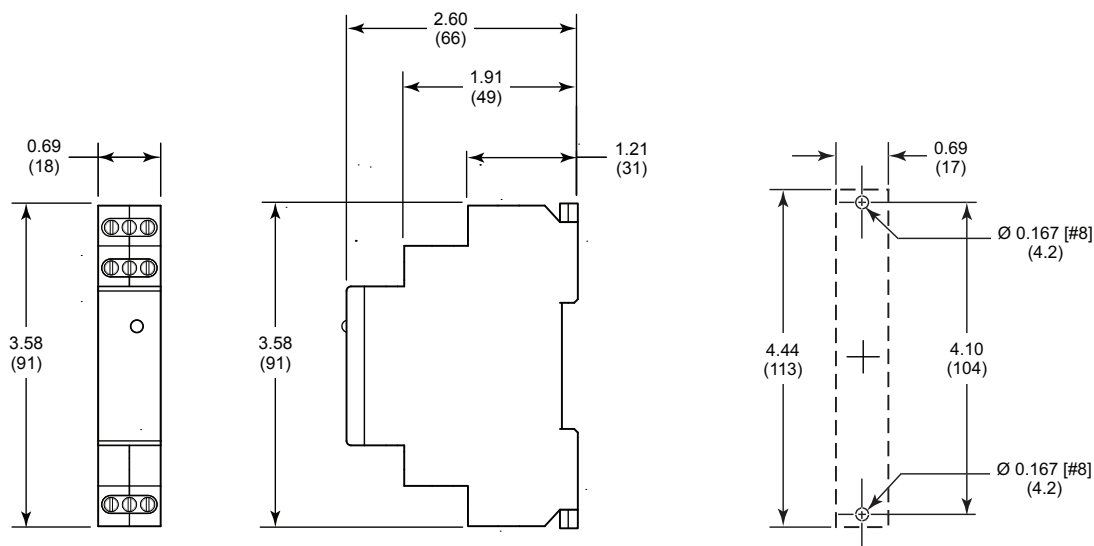

All Dimensions in Inches (Millimeters)

Panel Mount Template

PLUG-IN INTRINSICALLY SAFE BARRIER RELAYS

ISP SERIES

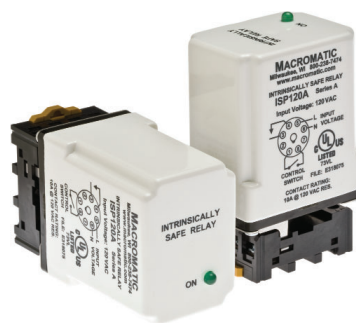

- ◆ Approved for use in these Hazardous Locations:
Class III, Div 1
- ◆ 1-Channel
- ◆ Terminals support 2-wire inputs
- ◆ Input voltage of 120V AC
- ◆ Isolated 10A relay output
- ◆ Plug-in design for easy installation and replacement
- ◆ LED status indicator



INTRINSICALLY SAFE BARRIER RELAYS | PLUG-IN

The ISP Series of Intrinsic Safe Barrier Relays provide a safe and reliable method to control a single load (motor starters, relays, etc.) with a single input device (switches, sensors, etc.) located in a hazardous area.

The ISP Series relay must be installed following Macromatic Control Drawing Number ISR2A01D as shown in Instruction Sheet 901-0000-260.

The ISP Series relays utilize an 8 pin plug-in design with socket (included) that can be both mounted on 35mm DIN rail or panel-mounted with two screws.

Operation

Each ISP Series relay consists of an intrinsically safe input and a corresponding normally-open relay output. There is one LED for status indication. With input voltage applied, the LED will be OFF. When the input device is closed, the output contact is closed and the LED is ON (Green). When the input device is open, the output contact is open and the LED will be OFF.

| CONTROL VOLTAGE 50/60Hz | NUMBER OF CHANNELS | CATALOG NUMBER | WIRING/SOCKETS ■ |
|----------------------------|--------------------|----------------|------------------|
| 120V AC | SINGLE | ISP120A | |

- The appropriate 8 pin socket is included with the plug-in relay.



Better. By Design.

800.238.7474

WWW.MACROMATIC.COM

SALES@MACROMATIC.COM

PLUG-IN INTRINSICALLY SAFE BARRIER RELAYS

ISP SERIES

APPLICATION DATA

Input Voltage:

120V AC, $\pm 10\%$, 50/60Hz

Load (Burden):

1.25 VA

Input Switch Open Circuit Voltage:

6V DC

Output Contacts:

SPST-NO 10A @ 120V AC Resistive

Life:

Mechanical: 10,000,000 operations

Full Load: 100,000 operations

Response Times:

Operate: 11 ms

Release: 4 ms

Temperature:

Operate: -20° to 60°C (-4° to 140°F)

Storage: -45° to 85°C (-49° to 185°F)

Insulation Voltage: 2,000 volts (between coil and contacts)

LED Indicator:

Green ON when output contact is closed and OFF when output contact is open.

Mounting:

The socket can be both mounted on 35 mm DIN rail or panel-mounted with two #8 screws.

Control Drawing:

See Instruction Sheet 901-0000-260, which includes Control Drawing ISR2A01D

Approvals:



DIMENSIONS

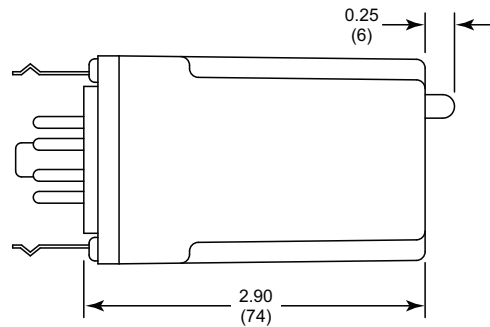
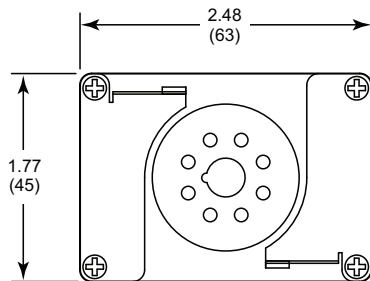

ISP Series

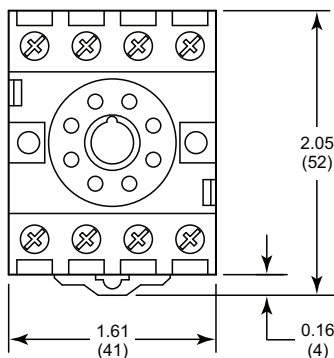

. Socket Provided with Relay

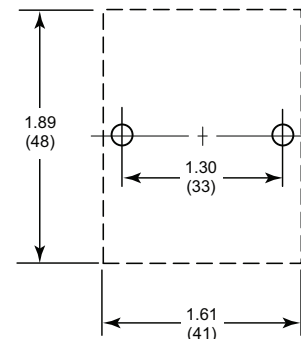
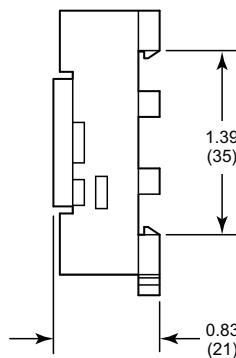

. Panel Mount Template

All Dimensions in Inches (Millimeters)

Your source for quality, innovative industrial control solutions

Macromatic Industrial Controls, Inc. designs and manufactures control, monitoring and protection products to manage your electrical processes and to protect your equipment from damaging fault conditions.

With a 45-year legacy of high-quality products and outstanding customer service, we continue to introduce innovative solutions that help our customers be more productive and efficient.

Our design and application experience makes it easy to find cost-effective advantages for your applications.

We continuously improve our products by integrating new technology and improving our manufacturing processes. The result is innovative reliable products, delivered on-time, every time.

www.macromatic.com

800.238.7474



Better. By Design.

Macromatic Industrial Controls Family of Products

MACROMATIC INDUSTRIAL CONTROLS

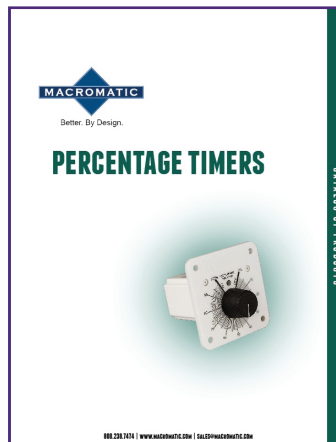
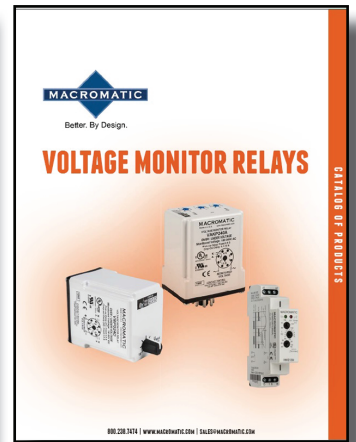
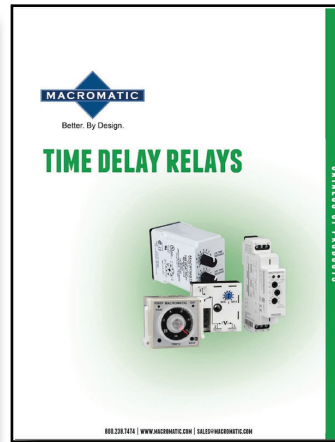

Better. By Design.

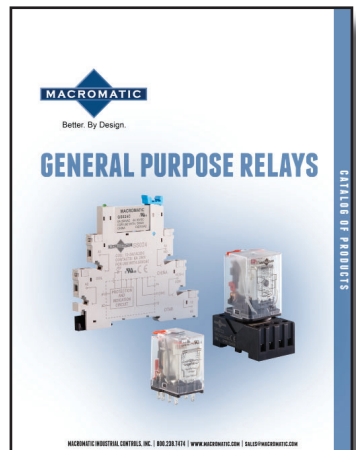

MACROMATIC INDUSTRIAL CONTROLS, INC. | 800.238.7474 | WWW.MACROMATIC.COM | SALES@MACROMATIC.COM

LCTGP00AEN0322

Specifications subject to change without notice | Macromatic is a registered trademark of Macromatic Industrial Controls, Inc.